



VIBRASWITCH® MALFUNCTION DETECTOR Model 368

GENERAL DESCRIPTION

The Robertshaw Model 368 PNEUMATIC VIBRASWITCH constitutes the most effective known method of avoiding costly damage due to mechanical malfunction of rotating and reciprocating machinery. In operation, the VIBRASWITCH actuates an audible warning system and/or shutdown circuit when vibration level of the VIBRASWITCH-PROTECTED equipment exceeds "normal" by a pre-selected amount. VIBRASWITCHES are widely used in permanent installations throughout the world; this versatile non-electric model requires only air or natural gas for operation.

Being non-electric, Model 368 may be employed in hazardous locations without the usual necessity of an explosion proof housing. This feature also makes the instrument well suited for applications at pipeline compressor stations and on skid-mounted compressors, as well as countless other applications.

The VIBRASWITCH is an acceleration sensitive instrument that measures the total acceleratory shock present on the machine. Acceleration is a vibration characteristic of prime importance in cases of mechanical failure on reciprocating or rotating machinery. Acceleration is directly related to the shock forces (impact) acting on a machine - thus the VIBRASWITCH offers a valid measurement of the destructive forces acting on the machine.

PRINCIPLE OF OPERATION

The Model 368 VIBRASWITCH employs a magnetic circuit opposed by the inertial force of the disturbing vibration. The armature is the only moving part when actuation occurs, and is constrained to movement in one plane by a frictionless flexure pivot. The pivot consists of two overlapping blocks and a leaf spring that is so loaded as to hold the blocks together. The armature rotates at the pivot, being forced in one direction by the adjusting spring and constrained in the opposite direction by the force of a permanent magnet.

When the instrument is subjected to vibration perpendicular to the base, resultant vibratory inertial force, aided by the adjusting spring, pulls the armature away from the hold down magnet. Magnitude of this inertial force is proportional to the mass of the armature and the acceleration component of the vibratory motion. When the peak acceleration exceeds the set point level, the armature breaks away from the stop pin, moving upward to open the pneumatic valve, which is normally closed maintaining a 15 psig pressure; on opening, inlet (controlled) line pressure drops to 3 psig or lower.

The pneumatic valve vents into the sealed cover and out the exhaust (vent) port. The decrease in control pressure actuates a pneumatic relay to initiate alarm or shut down of the malfunctioning equipment.

Operation of the reset valve will apply pressure to the reset piston, returning the VIBRASWITCH armature to the reset position. Returning the three-way reset valve to its normal position vents the reset piston and returns the reset piston to its normal position. Manual reset of the armature is also provided by a reset button.



VIBRASWITCH MODEL 368

FEATURES AND BENEFITS

- **ACCELERATION SENSITIVE** – Measures total destructive shock, not displacement.
- **NO MAINTENANCE** – No moving parts except when set-point is exceeded.
- **CONTINUOUS PROTECTION** - No attention required after installation
- **EASE OF INSTALLATION** - Requires no special training.
- **LONG LIFE** – Instrument is rugged and durable - no wearing parts.
- **EASE OF ADJUSTMENT** – Set it and forget it - one adjustment.
- **RESET** – Choice of remote pneumatic or manual at unit.
- **SELF POWERED** – Does not require any form of external power to operate.
- **LOW COST** – Small initial investment with no maintenance costs.

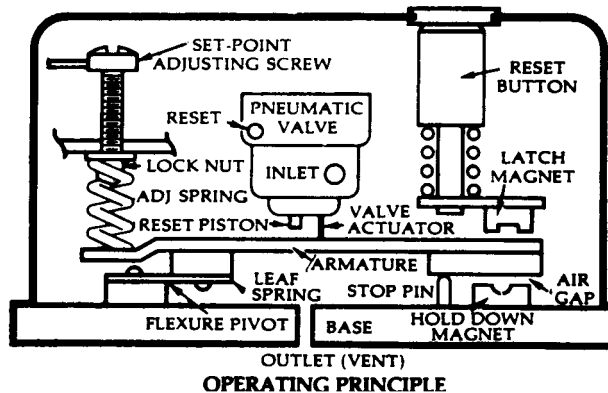

OPERATING PRINCIPLE

SPECIFICATIONS:

Inlet Pressure 15-50 psig
 Control Pressure (Tripped) 3 psig nominal
 Reset Pressure..... 15-50 psig
 Setpoint Range 0-4.5 g (peak), adjustable 1 g per turn
 Accuracy ± 5% of full range at frequencies
 0 to 300 Hz

Shock 40 g @ 11 ms maximum

SYSTEM OPERATING CONDITIONS:

Reset - No Flow..... Tripped - 0.266 SCFM @ 20 psig

ENCLOSURE MATERIALS:

Cover High impact, ABS Thermoplastic
 Base Type 360 (Cu Free) Aluminum

LOCATIONS Hazardous, outdoor, unprotected
 (NEMA-4)

WEIGHT:

Net 2 lbs.
 Shipping 2.5 lbs.

ORDERING INFORMATION

Specify complete model number from the table below.

Model No.	Description
368-R	Pneumatic Vibration Detector, Weather Resistant Housing. Range: 0-4.5 G. Pneumatic signal loss when setpoint is exceeded with manual and remote pneumatic reset provisions. Reset supply pressure 15-50 psig.

ACCESSORIES*
 (Must be ordered separately)

Part No.	Description
904GB014	.028 Orifice. Double ended male fitting. Mates with SAE 45° flared female fitting for 1/4" hose.
99448-A1	.028 Orifice. (1) 1/8 NPT male end and (1) 1/8 NPT female end.
83939-B21	Pneumatic relay. 1/8 NPT female connections
83939-F211	Reset valve, push-button. 1/8 NPT female connections.

* An Orifice must be connected to inlet of VIBRASWITCH for proper operation.

15 - 50 PSIG SUPPLY MANIFOLD (AIR OR NATURAL GAS)

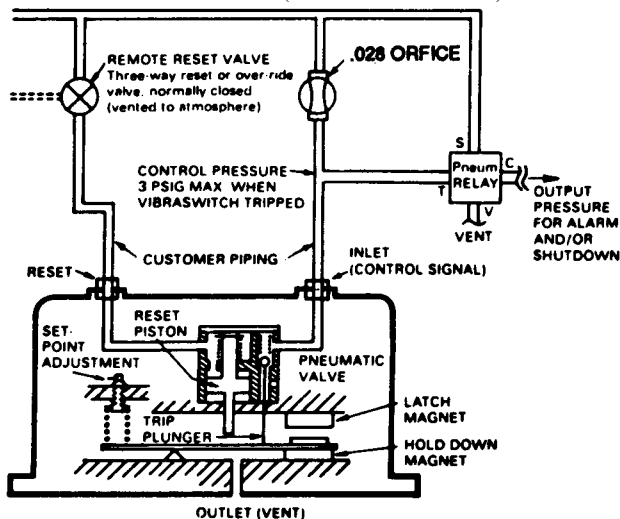

PIPING DIAGRAM - MODEL 368

MOUNTING DIMENSIONS

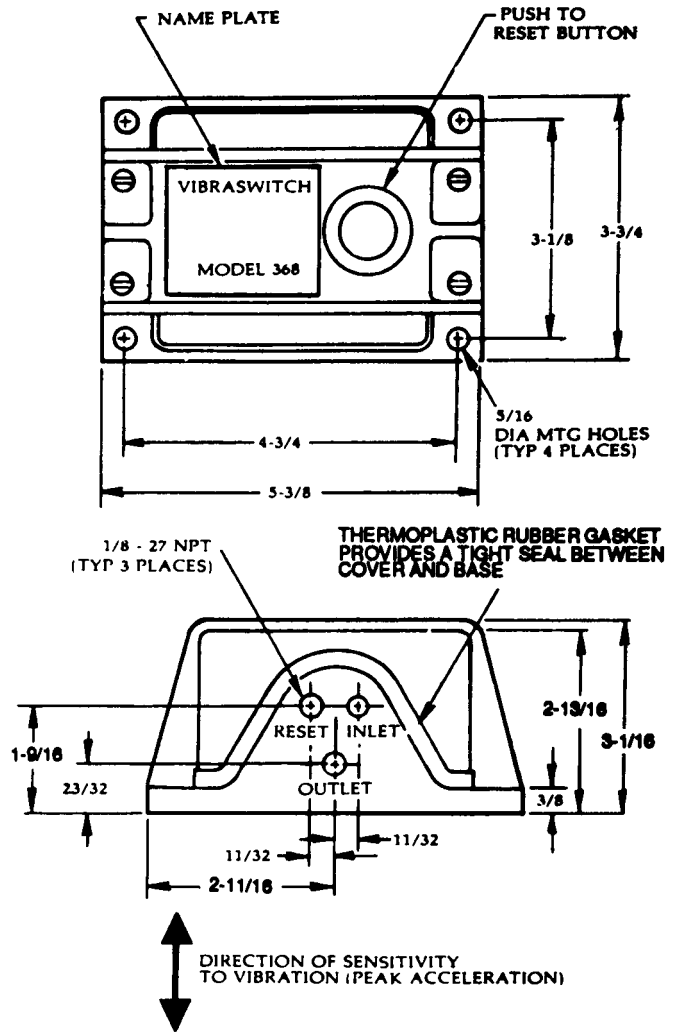

Robertshaw Industrial Products
 1602 Mustang Drive
 Maryville, Tennessee 37801
 Phone: (865) 981-3100 Fax: (865) 981-3168
<http://www.robertshawindustrial.com>