

Model 750 Probe

GENERAL DESCRIPTION

The Model 750 is an economical general purpose rigid probe for use with Robertshaw capacitance instruments. It is used for level measuring applications involving liquids or dry materials. Available either bare (non-insulated) or Teflon insulated for use in conductive solutions. The Teflon electrode insulation has a Teflon wall thickness of 1/16" over a 7/32" 316 stainless steel sensing rod. The Teflon insulated probe is recommended for use on low viscosity liquids and low to medium density granular materials. (For abrasive or agitated products, see Robertshaw Model 728B Heavy Duty probes.)

The Model 750 Probe has been designed to ensure long, trouble-free life. Extra tight fitting Teflon insulation has been incorporated into the design of the Model 750 Probe series. This insulation is continuous through the total length of the probe, including the gland. If a seal should break down and allow leakage into the gland, this internal construction is such that the measurement will not be affected and reliable readings will continue.

The Model 750 Probe, except as noted, conforms to the requirements of the National Association Of Corrosion Engineers (NACE) specification MR0175-88 (Material requirements For Resistance To Sulfide Stress Cracking For Oilfield Equipment).

APPLICATION DATA

When a probe is used with on-off (point level) instruments, it may be installed in the vessel either horizontally or vertically. For extremely small differential (deadband), the probe should be mounted in a horizontal position at the desired level point.

If the probe is to be used on a continuous level measurement application, the probe must be mounted in the vessel in a vertical position.

For low dielectric liquid applications, the Model 750 probe offers a concentric shield option over the sensing electrode.

Various gland materials and/or optional flanges are readily available to meet particular requirements.



- **Non-shortable Gland Assembly**
- **Extra tight Fitting Teflon Insulation**
- **Many Options Available to Tailor Probe to Customers' Needs**
- **Available in Lengths to 20 Feet**
- **No Moving Parts**
- **Conformance to NACE MR0175-88 (Certain Models)**

SPECIFICATIONS

Temperature/Pressure Ratings

Non-Insulated Probes-30" Hg to 1000 psi
 Up to 150°F.
 Derated to 0 psi @ 350°F.
 Insulated Probes-30" Hg to 1000 psi
 Up to 150°F.
 Derated to 0 psi @ 350°F.

Gland Capacitance 29pf

Probe Gain (insulated probe in
 conductive liquid) 60 pf/ft.

Sheath Capacitance 60 pf/ft.

ENGINEERING DATA

Probe Rod Material (standard) 316 stainless steel

Probe Length (maximum)..... 20 feet

Gland Connection Size3/4" NPT

Probe Diameter, Non-Insulated7/32" O.D.
 Insulated3/8" O.D.

Gland Materials:

Standard 316 stainless steel

Sheath Material 316 stainless steel

DIMENSIONAL DATA

MM
 INCH

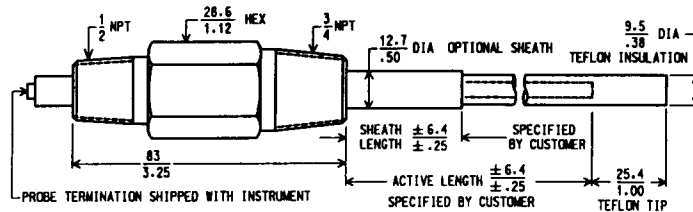

INSULATED PROBE

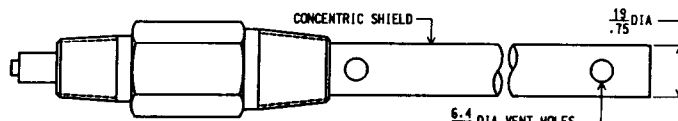

SHIELDED PROBE

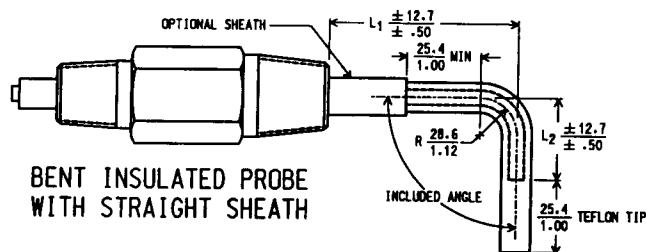

BENT INSULATED PROBE WITH STRAIGHT SHEATH

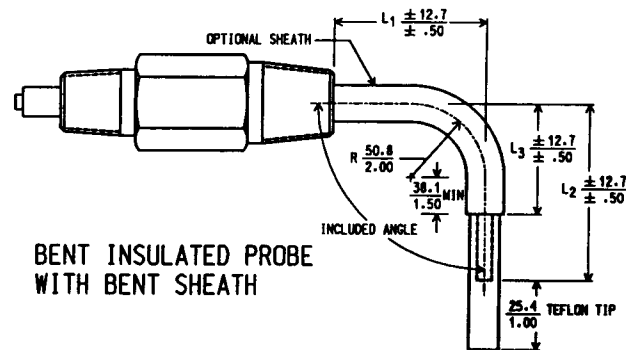

BENT INSULATED PROBE WITH BENT SHEATH

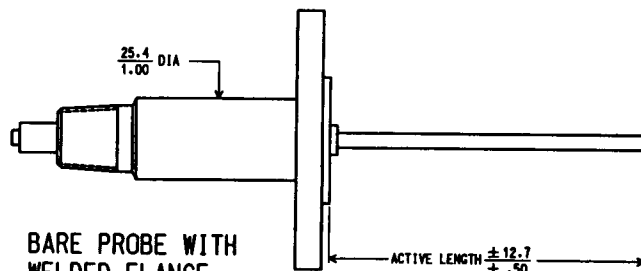

BARE PROBE WITH WELDED FLANGE

BEND DIMENSIONS

Probe Style	Minimum Lengths		
	L1	L2	L3
Basic Probe	2.00"	2.00"	-
With Straight Sheath	3.50"	2.00"	-
With Bent Sheath	3.50"	4.50"	3.50"
With Welded Flange	3.50"	2.00"	-
With Welded Flange and Straight Sheath	3.50"	2.00"	-
With Welded Flange and Bent Sheath	4.75"	4.50"	3.50"

ORDERING INFORMATION

Specify complete model number according to the tables below.

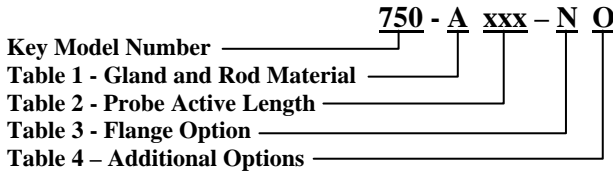

KEY MODEL NUMBER

Model No.	Description
750	Economical general purpose capacitance probe. The probe utilizes a non-shortening gland assembly.

Table 1 - GLAND AND ROD MATERIAL

Desig.	Description
A	316 St. St. gland and 7/32" bare rod
B	316 St. St. gland with 3/8" O.D. Teflon over 7/32" rod

Table 2 - PROBE ACTIVE LENGTH

Desig.	Description
xxx	*Specify active length in inches. Maximum length is 240". For insulated probes the insertion length is 1" longer than the active length due to the Teflon Tip.

*For probes with sheath, length is active length plus sheath length

Table 3 - FLANGE OPTION

Desig.	Description
N	None
A	Flange Screwed onto probe gland. Specify size and material.
B	Flange welded to probe gland. Specify size and material.

Table 4 - ADDITIONAL OPTIONS

Desig.	Description
0	None
1	Bent Probe. Specify Bending Dimensions. See Bending Dimension table and drawings.
2*	Sheath, same material as gland. Specify Sheath Length.
3*	Combination of 1 & 2 above.
4	Ground Wire Probe. Specify Material.
5*	Concentric shield, same material as gland.

* Does not conform to NACE MR0175.

Standard Flange Sizes

1" Class 150 Raised Face
1-1/2" Class 150 Raised Face
2" Class 150 Raised Face
3" Class 150 Raised Face
4" Class 150 Raised Face
1" Class 300 Raised Face
1-1/2" Class 300 Raised Face
2" Class 300 Raised Face
3" Class 300 Raised Face
4" Class 300 Raised Face

Standard Flange Materials

* Carbon Steel
* 316 Stainless Steel
316L Stainless Steel

* Does not conform to NACE MR0175.

Ground Wire Materials

* 316 Stainless Steel
316L Stainless Steel (not for dry products)
* Monel
* Hastelloy B
* Hastelloy C
* Tantalum

* Does not conform to NACE MR0175.

NOTES:

1. The insertion length for insulated probes is 1" longer than the active length due to the Teflon Tip which is required for sealing the probe. For bare probes the insertion length is the same as the active length.
2. For simple bent probes, specify dimensions L₁, L₂, the included angle and, if the sheath is bent, L₃ as shown in the drawings. For more complicated bending submit a sketch with the order.
3. Probes may be supplied with flanges of different sizes, styles and materials than listed above by special order.



Robertshaw Industrial Products
1602 Mustang Drive
Maryville, Tennessee 37801
Phone: (865) 981-3100 Fax: (865) 981-3168
<http://www.robertshawindustrial.com>

Q-4156 (1/08)

Printed in U.S.A